

# TO STUDY THE EFFECT OF BAMBOO AND STEEL AS REINFORCEMENT ON STRUCTURE

**Manjesh Srivastava<sup>1</sup>, Kuldeep Sharma<sup>2</sup>, Vikas Kumar<sup>3</sup>, Sunayna<sup>4</sup>**

1. Madan Mohan Malaviya University of Technology, Gorakhpur
2. Dr B R Ambedkar National Institute of Technology, Jalandhar
3. Madan Mohan Malaviya University of Technology, Gorakhpur
4. CSIR-NEERI, Mumbai Zonal Centre

**ABSTRACT.** Bamboo has been by tradition used as a building material and in present-day used in low cost housing, building temporary structures and other home- grown architectural expressions. In a building the walls, slabs, beams and column are the most important sections, which can be analyzed distinctively based on the needs, thus, improving the speed of construction and reducing the construction cost. With the advancement of science and technology and the tight supply of timber, new methods are needed for the processing of bamboo to make it more durable and more usable in terms of building materials. Bamboo has several unique advantages like ability to grow fast with a high yield and also it matures quickly. In this paper we point out the various aspects of predestined building methodologies by highlighting the different available techniques, and the economical advantages achieved by its adoption. This paper compares the cost of steel reinforcement with bamboo reinforcement by designing of two way slab and doubly reinforced beam. To study the effect of replacement of steel reinforcement by bamboo reinforcement, designs have been conducted on the span of two way slab of size 3650 x 4570 sq-mm with providing beams. The information in this report has been compiled from reports of test programs by various researchers and represents current opinion. In this paper the designs are done on the calculation of loads according to IS 456:2000 and compare the costs of structure by design of structure.

**Keywords:** Bamboo, Flexural Strength, Cost Estimation, Economical.

**Manjesh Srivastava** is an Assistant Professor in the Department of Civil Engineering, Madan Mohan Malaviya University of Technology, Gorakhpur.

**Kuldeep Sharma** is Research Scholar in Dr B R Ambedkar National Institute of Technology, Jalandhar. His research area are sustainable material, fatigue analysis, leachate.

**Vikas Kumar** is an Assistant Professor in the Department of Civil Engineering, Madan Mohan Malaviya University of Technology, Gorakhpur.

**Sunayana** is Scientist in National Environmental Engineering Research Institute, Mumbai Zonal Lab. Her Research includes the application of artificial Intelligence in Civil Engineering.

## INTRODUCTION

In recent times, the high cost and general shortage of reinforcing steel in many parts of the world has led to increasing interest in the possible use of alternative locally available materials for the reinforcement of concrete. This is the case especially in the developing countries where about 70% of the population lives in villages [5,6]. Bamboo is an energy efficient and environmentally sustainable material in nature. The steel as a reinforcing material is increasing daily in most of the developing countries but there is a situation when the production of steel is found costly. So, use of bamboo is an alternative solution to overcome from the cost effectiveness when compared to steel [7,8]. The general properties of bamboo have been extensively studied by a number of researchers including Yu et al. (2008), Cao and Wu (2008), Ghavami (2005), Khare (2005), Amada (1997), and Kankam and Perry (1989) to name a few which shows that Bamboo is an anisotropic material and shrink more than wood when it loses water. Bamboo shrinks in a cross section of 10-16 % and a wall thickness of 15-17 %. Therefore it is necessary to take necessary measures to prevent water loss when used as a building material and also bamboo able to resist more tension than compression. The tensile strength of these fibres is higher than that of steel as a comparison; extremely strong wood fibers can resist a tension up to 50 N /mm<sup>2</sup>. Bamboo also shows the accumulation of highly strong fibers in the outer parts of the tube wall which also work positive in connection with the elastic modulus like it does for the tension, shear and bending strength. The higher the elastic modulus, the higher is the quality of the bamboo. Enormous elasticity makes it a very useful building material in areas with very high risks of earthquakes. However, the purpose of this study was to compare the cost of bamboo reinforcement which is used on building structure instead of steel reinforcement. To study the effect of bamboo reinforcement slab and beams, selection and preparation of bamboo is necessary. The selection and preparation of bamboo have been studied by researchers including Francis E. Brink and Paul J. Rush and select that bamboo which shows a pronounced brown colour and largest diameter culms of bamboo[4,10] i.e. 35 mm diameter use over a span of size 3650 x 4570 sq-mm with proper preparation i.e. waterproof coatings in this type of coating a thin coating should be applied over the length of bamboo and a thick coating will lubricate the surface and weaken the bond with the concrete [4,10].

Table 1 Specific Properties of Bamboo [1]

PROPERTIES	VALUES
Specific gravity	0.575 to 0.655
Average weight (kg/m)	0.625
Modulus of rupture (kg/cm <sup>2</sup> )	610 to 1600
Modulus of Elasticity (kg/cm <sup>2</sup> )	1.5 to 2.0 x10 <sup>5</sup>
Ultimate compressive stress (kg/cm <sup>2</sup> )	794 to 864
Safe working stress in compression (kg/cm <sup>2</sup> )	105
Safe working stress in tension (kg/cm <sup>2</sup> )	160 to 350
Safe working stress in shear (kg/cm <sup>2</sup> )	115 to 180
Bond stress (kg/cm <sup>2</sup> )	5.6

It is clear from literature survey that this bamboo reinforcement technique is absolutely cheaper than steel reinforcement technique especially for single story structure. It is considered to be sustainable and renewable alternative to hardwoods, foremost because it regenerates at exceptionally fast rates. It is cost-effective, especially in areas where it is cultivated and is readily available. Transporting lightweight bamboo is less costly than transporting its heavier alternatives. Bamboo reinforcement technique is used for both main and distribution reinforcement as it was same earlier done for steel reinforcement. The energy required in processing bamboo is less than for concrete, wood, and steel. For the designing of two way slab and doubly reinforced beam by the use of bamboo as reinforcement we consider the following properties of bamboo

## CASE STUDY FOR SLAB AND BEAM

To show the advantage of bamboo as reinforcement instead of steel, slab and beam is designed by using steel and bamboo as a reinforcement with M 20 grade of concrete.

### Slab:

Slabs are plate elements forming floors and roofs of buildings and carrying distributed loads primarily by flexure. Moreover, a slab may be simply supported or continuous over one or more supports and is classified according to the manner of support i.e. one way slabs spanning in one direction, that is supported on two opposite edges and two way slab spanning in both direction, that is supported on four edges. A two way slab may be considered to consist of a series of interconnected beams as shown in fig. 1 [3].

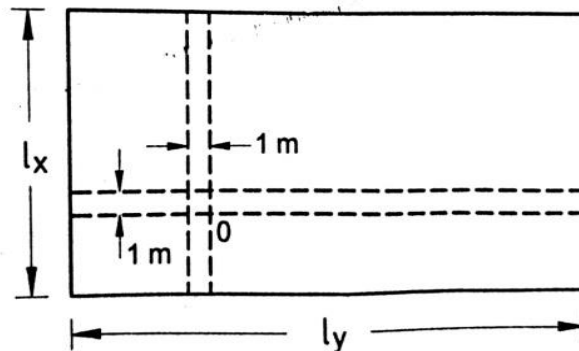

Figure 1 Two -way Slab

Where,

$l_y$  is the longer span

$l_x$  is the shorter span

For the designing of two way slab we take:

length of the span  $l_y = 4.57$  m

$l_x = 3.65$  m

Span Ratio  $l_y/l_x = 1.25$  Two Way Slab

## Design of Two Way Slab

For the designing of two way slab by bamboo and steel reinforcement first of all we have to calculate a factored load and coefficients of two way slab from the code of IS 456:2000 which is same for both.

Table 2 Calculation of Factored Load

LOADS		CALCULATIONS
Dead load of Slab	=	$0.18 * 25 = 4.5 \text{ kN/m}^2$
Live Load	=	$2 \text{ kN/m}^2$
Floor Finish Load	=	$1.5 \text{ kN/m}^2$
Total Load	=	$8 \text{ kN/m}^2$
<b>Factored Load</b>	=	<b><math>12 \text{ kN/m}^2</math></b>

Table 3 Coefficients of two way slab from IS-456:2000

COEFFICIENTS		VALUES
$\beta_x(-)$	=	0.080
$\beta_x(+)$	=	0.060
$\beta_y(-)$	=	0.047
$\beta_y(+)$	=	0.035

## For Steel Reinforcement

### Moments

$M_x(-)$	=	16.22	$\text{kN/m}^2$
$M_x(+)$	=	12.16	$\text{kN/m}^2$
$M_y(-)$	=	9.53	$\text{kN/m}^2$
$M_y(+)$	=	7.09	$\text{kN/m}^2$

Effective depth of Slab "d" = **76.65 mm**

**Adopt 100 mm effective depth and 120 mm overall depth**

**D 120 mm**

### Reinforcements

$A_{st\ x(-)}$	=	489.28	$\text{kN/m}^2$	Use 10 mm bars @ 160.441
$A_{st\ x(+)}$	=	356.00	$\text{kN/m}^2$	Use 10 mm bars @ 220.506
$A_{st\ y(-)}$	=	273.82	$\text{kN/m}^2$	Use 10 mm bars @ 286.68
$A_{st\ y(+)}$	=	200.68	$\text{kN/m}^2$	Use 10 mm bars @ 391.165

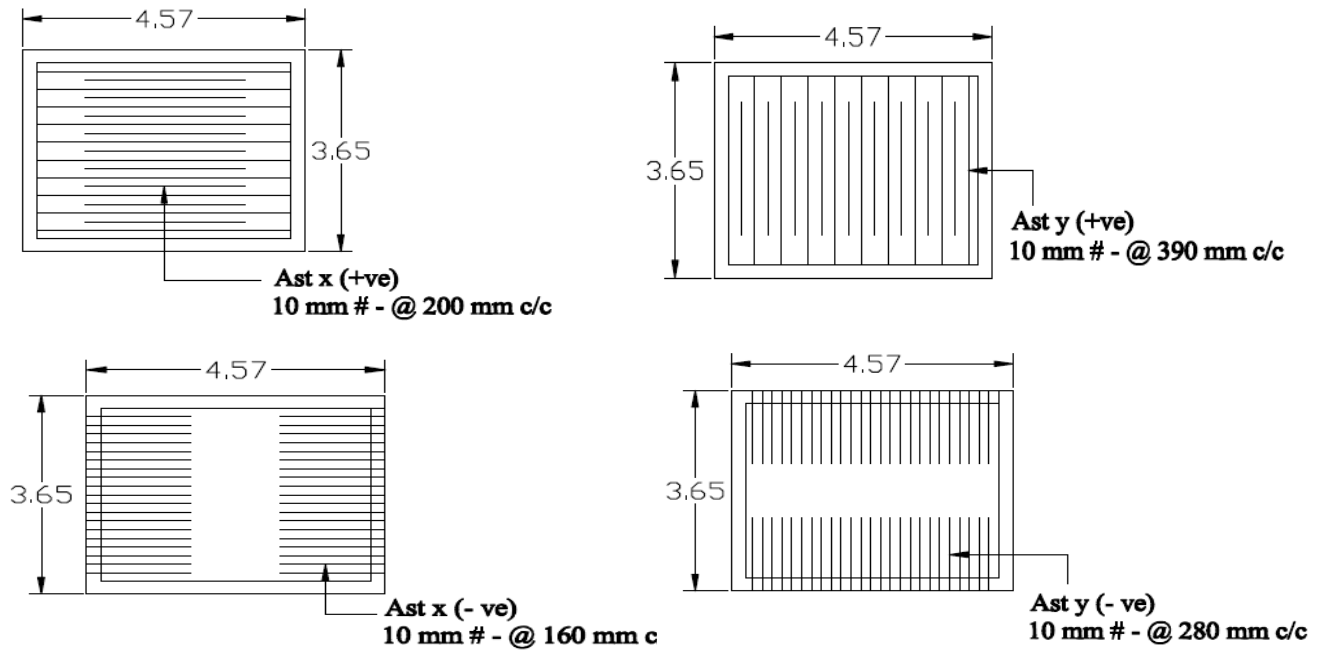

Figure 2 Steel reinforcement of Two Way Slab

### For Bamboo Reinforcement

#### Moments

$M_x(-)$	=	16.22	kN/m <sup>2</sup>
$M_x(+)$	=	12.16	kN/m <sup>2</sup>
$M_y(-)$	=	9.53	kN/m <sup>2</sup>
$M_y(+)$	=	7.09	kN/m <sup>2</sup>

Effective depth of Slab "d" = **76.65 mm**

**Adopt 100 mm effective depth and 120 mm overall depth**

**D 120 Mm**

#### Reinforcements

$A_{st\ x(-)}$	=	4060.98	kN/m <sup>2</sup>	Use 30 mm bars @ 140 mm c/c
$A_{st\ x(+)}$	=	2954.79	kN/m <sup>2</sup>	Use 30 mm bars @ 200 mm c/c
$A_{st\ y(-)}$	=	2272.74	kN/m <sup>2</sup>	Use 30 mm bars @ 400 mm c/c
$A_{st\ y(+)}$	=	1665.66	kN/m <sup>2</sup>	Use 30 mm bars @ 200 mm c/c

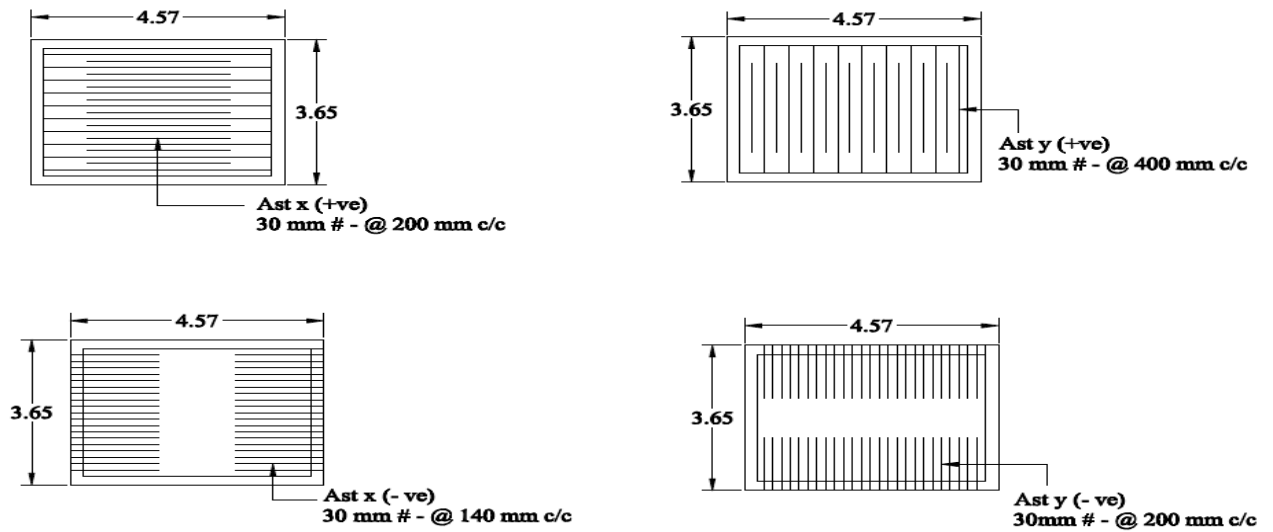

Figure 3 Bamboo Reinforcement of Two Way Slab

## Beam

A reinforced concrete flexure member may be a beam, slab, wall or component of foundation. There are two types of beams singly reinforced beam and doubly reinforced beam. In singly reinforced section reinforcing steel bars are placed in tension zone while in doubly reinforced section reinforcing steel bars are placed in both tension and compression zone [3].

## Design of Doubly Reinforced Beam

### For Steel Reinforcement

Max. bending moment ( $M_u$ ) =	31.32735	KN-m
Q =	0.138 x 20	
$M_{u\ lim}$ =	20.56752	KN-m
effective depth (d) =	180	mm
Say	230	mm

### Area of steel (Tension)

Ast 1 =	395.5961778	mm sq.
Ast 2 =	229.2422741	mm sq.
Ast (Tension) =	624.838452	mm sq.

**Use 16 mm # - 3 No.**

### Area of steel (Compression)

$$\begin{aligned}x_u \text{ lim} &= 86.4 \\E_{sc} &= 0.001474537 \\F_{sc} &= 361.05 \quad \text{N/mm sq.} \\A_{sc} \text{ (Compression)} &= 235.1027498 \quad \text{mm sq.}\end{aligned}$$

Use 12 mm # - 2 No.

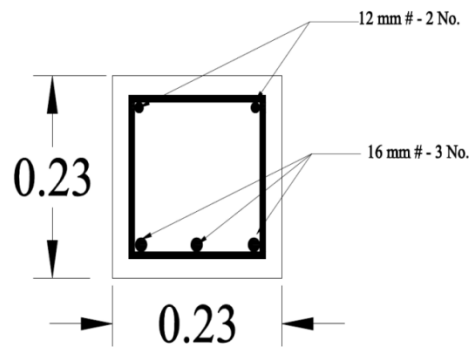

Figure 4 Doubly Reinforced Beam of Steel Reinforcement

### For Bamboo Reinforcement

$$\begin{aligned}\text{Max. bending moment ( } M_u \text{ )} &= 51.62 \quad \text{KN-m} \\Q &= 0.138 \quad * f_{ck} \\M_{u \text{ lim}} &= 20.56752 \quad \text{KN-m} \\ \text{effective depth (d)} &= 250 \quad \text{mm} \\ \text{Say} &= 300 \quad \text{mm}\end{aligned}$$

### Area of steel (Tension) :

$$\begin{aligned}A_{st 1} &= 4560.344828 \quad \text{mm sq.} \\A_{st 2} &= 1373.527299 \quad \text{mm sq.} \\A_{st} \text{ (Tension)} &= 5933.872126 \quad \text{mm sq.}\end{aligned}$$

Use 35 mm # - 3 No.

### Area of steel (Compression)

$$\begin{aligned}x_u \text{ lim} &= 86.4 \\E_{sc} &= 0.001474537 \\F_{sc} &= 361.05 \quad \text{N/mm sq.} \\A_{sc} \text{ (Compression)} &= 169.715 \quad \text{mm sq.}\end{aligned}$$

Use 16 mm # - 2 No.

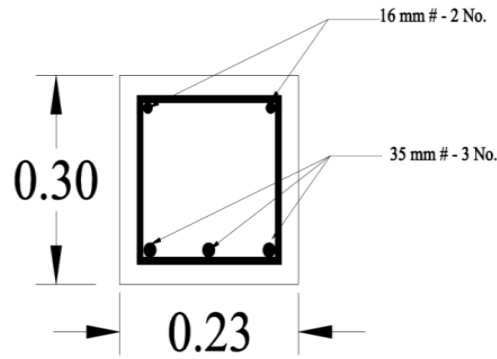

Figure 5 Doubly Reinforced Beams for Bamboo Reinforcement

## RESULTS AND DISCUSSIONS

If we compare the quantity of steel and bamboo as reinforcement on structure we found that bamboo as reinforcement use in large amount from steel. So according to the quantity if we estimate the cost of steel and bamboo we can say that bamboo is much cheaper than steel because bamboo is cheaper than steel and on the basis of designing we also ensure its safety by its strength and stability [9].

Table 4 Cost of Steel and Bamboo as Reinforcement

ITEM	BAMBOO (RS)	STEEL (RS)
Slab	18416	40341
Beam	2280	10080
<b>Total</b>	20696	50421

## CONCLUSIONS

From the given paper we conclude the advanced bamboo reinforcement technique instead of steel reinforcement and following results were obtained

- In the designing of two way slabs depth is 110 mm for both steel and bamboo reinforcement but the diameter of bamboo is used maximum instead of steel reinforcement.
- In the designing of doubly reinforced beam, depth is 300 mm when we design with bamboo reinforcement and 230 mm when we design with steel reinforcement.
- On the construction of structure i.e. two way slabs and doubly reinforced beams we found cost of bamboo reinforcement is minimum from steel reinforcement.
- Tensile strength of bamboo is good and can be used as reinforcement in R.C.C structure for low cost housing project.
- It is clear from results that this bamboo reinforcement technique is absolutely cheaper than steel reinforcement technique especially for single story structure.



## **ACKNOWLEDGMENTS**

This work has been carried out in civil engineering department of Madan Mohan Malaviya University of Technology, Gorakhpur, India. The authors present its heartiest gratitude towards the entire faculty members for their constant encouragements, guidance and supports.

## **REFERENCES**

1. Anurag Nayak<sup>1</sup>, Arehant S Bajaj<sup>2</sup>, Abhishek Jain<sup>3</sup>, Apoorv Khandelwal<sup>4</sup>, Hirdesh Tiwari<sup>5</sup> “Replacement of Steel by Bamboo Reinforcement”.
2. Francis E. Brink and Paul J. Rush, “Bamboo Reinforced Concrete Construction”
3. Ashok K. Jain, “Reinforced Concrete Limit State Design”.
4. Pratish Kumar Singh<sup>1</sup>, Aashish Jodhani<sup>2</sup>, Abhay Pratap Singh<sup>3</sup>, “Bamboo as Construction Material and Bamboo Reinforcement”.
5. Adom Asamoah<sup>1</sup>, Mark Afrifa Owusu<sup>2</sup>, Russell<sup>3</sup>, “A Comparative Study of Bamboo Reinforced Concrete Beams Using Different Stirrup Materials for Rural Construction”.
6. Sanjeev Gill<sup>1</sup>, Dr Rajiv kumar<sup>2</sup>, “To Experimental Study And Use of Bamboo In Civil Structure as Reinforced Concrete
7. Bhalla, S., Janssen J.A.J “Design Bamboo as Green Alternative to Concrete and Steel for Moder Structures.”
8. Chariar.V.M. “Fabrication and Testing of Jute Reinforced Engineered Bamboo Structural Elements.”
9. Dutta, B.N. “Estimate & Costing in Civil Engineering.”
10. Francis E. Brink and Paul J. Rush “Bamboo Reinforced Concrete Construction.”